

FORK MOUNTED DRUM GRIPPERS - FDG-30

APPROX WEIGHT: 82.12 lbs.
DOES NOT INCLUDE WEIGHT OF POWER OR PACKAGING!!!

*** ANY ADDITIONS, DELETIONS, OR OMISSIONS MUST BE CORRECTED ON THIS DRAWING AS THIS DRAWING WILL BE CONSIDERED ALL INCLUSIVE ***

ALL GRAPHICS PROVIDED ARE FOR REFERENCE ONLY. IF CERTAIN DIMENSIONS ARE CRITICAL PLEASE VERIFY THOSE DIMENSIONS WITH YOUR SALESPERSON

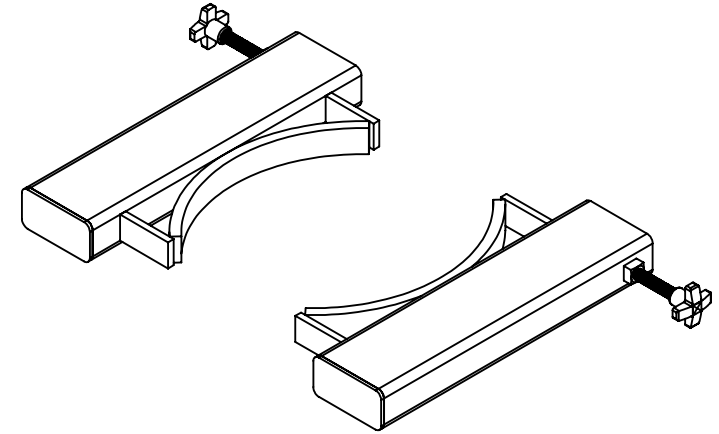
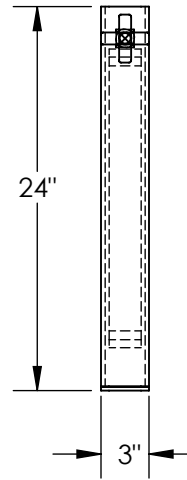
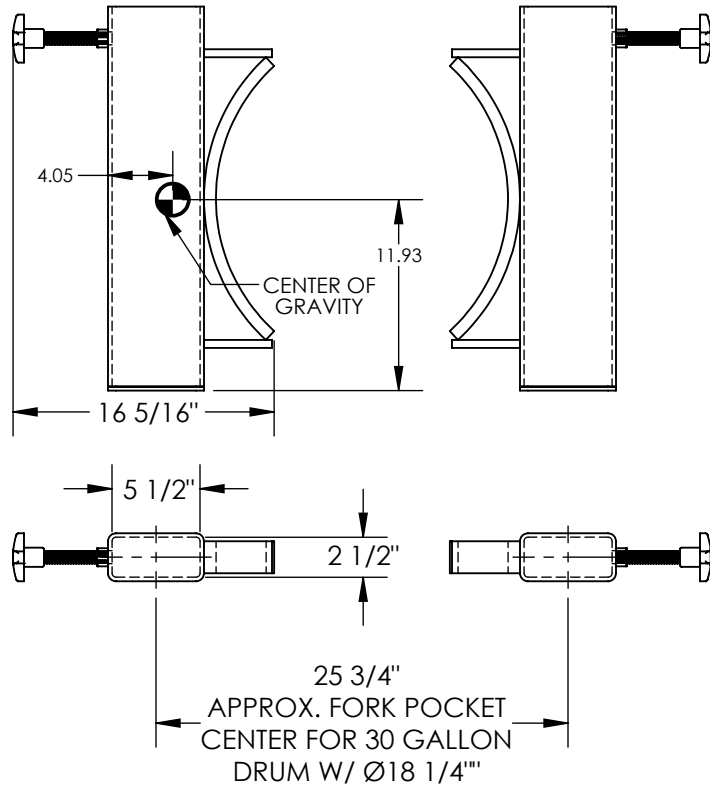

STANDARD FEATURES

- MODEL NUMBER IS FDG-30
- MAXIMUM WIDTH OF SINGLE FORK GRIPPER IS $16 \frac{5}{16}$ "
- OVERALL LENGTH OF SINGLE FORK GRIPPER IS 24"
- OVERALL HEIGHT IS OF SINGLE FORK GRIPPER IS 3"
- USABLE WIDTH FORK POCKET IS $5 \frac{1}{2}$ "
- USABLE HEIGHT FORK POCKET IS $2 \frac{1}{2}$ "
- MAX CAPACITY IS 800 LBS
- PICKS UP 30 GALLON DRUM
- TOUGH BAKED IN POWDER COATED BLUE FINISH

SPECIAL FEATURES

NONE

DIMENSION TOLERANCE $\pm 1/4$ "

APPROVAL	I, THE UNDERSIGNED, AGREE THAT THE PRODUCT AS REPRESENTED SATISFIES DESIGN AND DIMENSION REQUIREMENTS. I ALSO ACKNOWLEDGE MY DUTY TO CONFIRM PRODUCT AND INSTALLATION COMPLIANCE WITH ALL APPLICABLE FEDERAL, STATE AND LOCAL REGULATIONS AND STANDARDS.	
	UNITS REQUIRING APPROVAL DRAWINGS OR MODIFIED ARE NON-RETURNABLE	
	[] As drawn [] As marked	
	Signed: _____	Date: _____
Printed Name: _____		
<i>LEAD TIME WILL START UPON RECEIPT OF SIGNED APPROVAL DRAWING</i>		

DISTRIBUTOR'S NAME:		P.O.#
VESTIL MANUFACTURING		X
DRAWN BY: BCN		DATE: 8/12/2016
REFERENCE: X		SCALE: 1:12
QUOTED LEAD TIME: X	QUOTE # X	SALES: X
		FILE NAME: 40-007-024-001